

# Hendricks Buddy Keyer/Speaker Console

## Assembly Manual



This Hendricks kit provides the builder with an audio amplifier, with speaker, and keyer using KD1JV's SKC (simple keyer chip) in a custom compact brushed aluminum chassis for desktop or field operations. It is ideal for any earphone only and or key only device. Steve's microcontroller chip employs two 29 character memories, adjustable speed from 5-40 wpm, sleep mode for low power consumption, and beacon mode. It is powered by an internal 9v battery, but can also be powered externally, via the 2.1mm power jack that is reverse polarity protected. With the removal of an internal jumper, you may also use this as a standalone code practice oscillator with your paddle.

The kit comes complete with all the electrical/mechanical components, chassis, and decals. It uses all through hole components, and can be easily assembled with the normally available kit building tools. Current during receive ~10mA, keying ~20mA.

Total assembly time 1~2 hours. Battery not supplied.

We'll start the kit process by identifying and matching the parts with the list below.

### **Electrical parts**

Qty.	Part	Description
1	R1	22K 1/4 watt resistor (red-red-orn)
1	R2	10 ohm 1/4watt resistor (brn-blk-blk)
1	R3	10K potentiometer w/S2 switch
2	R4,R5	2.2K 1/4 watt resistor (red-red-red)
2	C1, C6	.1uF capacitor yellow, marked (104)
3	C2, C3, C4	.01uF capacitor yellow, marked (103)
1	C5	.047uF capacitor, yellow, marked (473K)
1	C7	.001uF capacitor yellow, marked (102)
3	C8, C9, C11	10uF electrolytic capacitor
1	C10	100uF electrolytic capacitor
1	U1	ATTINY13, 8 pin dip microcontroller IC
1	U2	LM386, 8 pin dip amplifier IC
1	U3	78L05 voltage regulator
2	Q1, Q2	2N7000 MOSFET transistor
1	D1	1N4004 diode
1	D2	LED, red
3	J1, J3, J4	Stereo PCB jack
1	J2	DC power jack w/switch
1	S1	Rt. angle pcb push button switch
1		8 pin dip ic socket
1		2" speaker
1		9V battery clip
1		2 pin header and jumper
5'		24awg hook-up wire
1		Printed circuit board

### **Mechanical parts**

1	Chassis, base and cover
2	Speaker retainer clips
2	4-40 x 1/4 pan head screw
2	4-40 x 1/4 flat head screw
2	4-40 x 3/8 flat head screw
2	2mm x 8mm pan head screw
2	2mm hex nut
1	Instrument knob
4	Self adhesive rubber feet
1	Decal set

Installing the decals to the chassis is addressed at the end of this document, in Appendix A.

Any first time kit builder should not proceed until you are confident that you can identify each part. There are many forums and contacts for Hendricks kits that can assist you for any questions that you may have.

All the pcb components mount on the silk screened side of the board. We will start by installing the smallest and shortest components first. Refer to the graphic below to guide you through the process. Check the items off as they are completed. Clip all leads on the back side 1/16" or shorter.

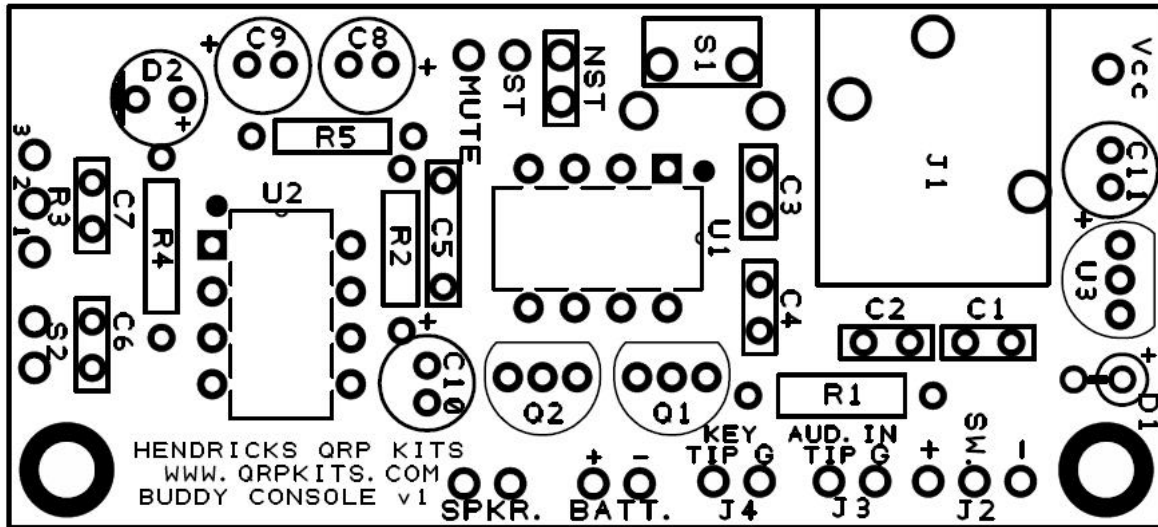

- Install and solder R1, 22K (red-red-orn)
- Install and solder R2, 10 ohm (brn-blk-blk)
- Install and solder R4, R5, 2.2K (red-red-red)
- Install and solder C1, C6, .1uF, yellow, marked (104)
- Install and solder C2, C3, C4, .01uF, yellow, marked (103)
- Install and solder C5, .047uF, green, marked (473K)
- Install and solder C7, .001uF, yellow, marked (102)
- Install and solder the 8 pin IC socket at U1, the notched end of the socket should match the silk screened outline. The pin 1 corner of the pads is also designated by a square pad at the upper left corner.
- Install and solder U2, the NJM386BD. The printed dot or recessed dot designates pin 1. It must align with the square pad at the U2 position. **Be sure you know which is pin 1, as ic's are difficult to remove without damaging the board.**

- Install and solder U3, 78L05 voltage regulator, matching the flat with the silk screen outline.
- Install and solder Q1 and Q2, 2N7000 transistors, matching the flats with the silk screen outlines.
- Install and solder S1, the right angle push button switch. Solder the two mounting tabs as well. Be sure to clip the mounting tabs and switch leads on the backside.
- Install and solder D1, 1N4004, vertically, with the **BAND END UP**, matching the board outline. The component is near the edge, with the looped lead towards the center of the board.

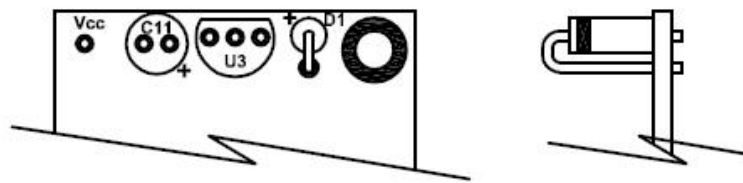

- Install and solder J1, one of the stereo jacks, to the pcb.
- Install the 2 pin header at the NST pads.
- Install and solder C8, C9, C11, the 10uF electrolytic capacitors. The long lead is **POSITIVE** and must match the "+" hole marked on the pcb.
- Install and solder C10, 100uF electrolytic capacitor. The long lead is **POSITIVE** and must match the "+" hole marked on the pcb.
- Installing D2, the red power on led, so that it protrudes through the front panel of the chassis requires that you carefully bend the leads 90 degrees, and solder to the pcb as shown in the graphic below. The long lead is **POSITIVE** and must go into the "+" pad.

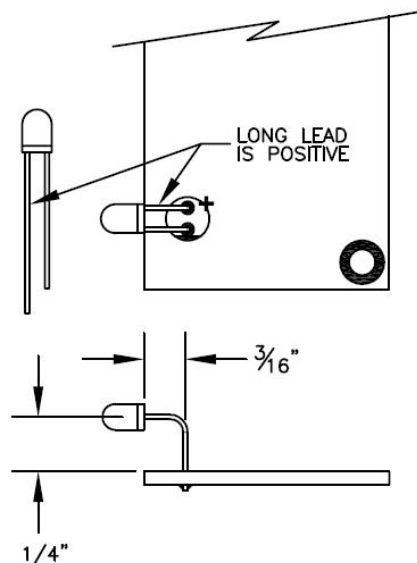

- Cut 12 pieces of 24awg hook-up wire, 3” long, and solder them to the following pads of the pcb. J2, J3, J4, S2, and R3.

The board should now look like the picture below.

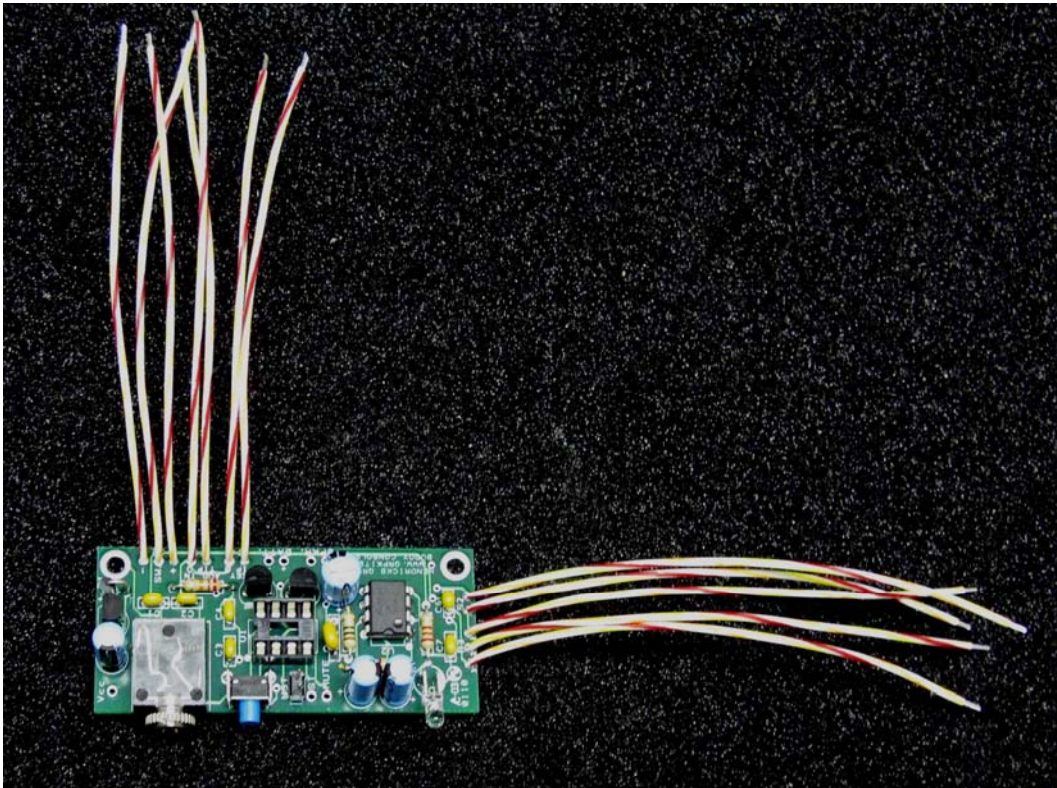

- Shorten tin the red and black wires connected to the speaker to about 4” long.
- Solder the supplied 9v battery snap connector to the BATT. terminals. **Red to “+”** and **black to “-”**.

At this point you are ready to attach the remote components to the board. I prefer to leave the leads long, and just tack them during testing, then trim and re-solder to the remote components as required when mounting into the chassis.

- Solder J3, J4, the stereo jacks. Only the tip and ground are used for both jacks. Solder J2 the DC power jack as shown to the leads.

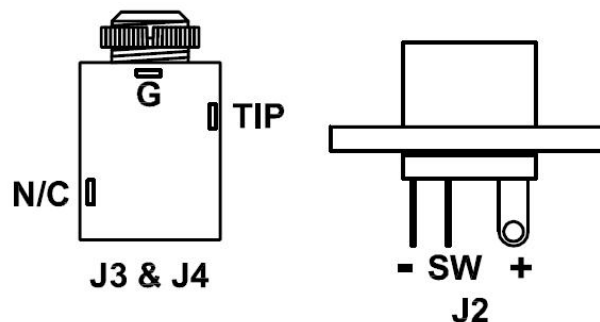

- Solder the speaker to the two leads marked SPKR.
- The potentiometer, R3/S2, must be prepared to fit into the case. Bend all 5 tabs to the rear, 90 degrees. Then solder the numbered leads to the pcb as shown, so the gain will increase as you turn the knob clockwise, and solder the switch connections for S2.

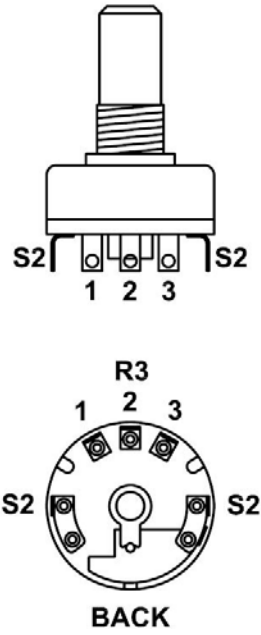
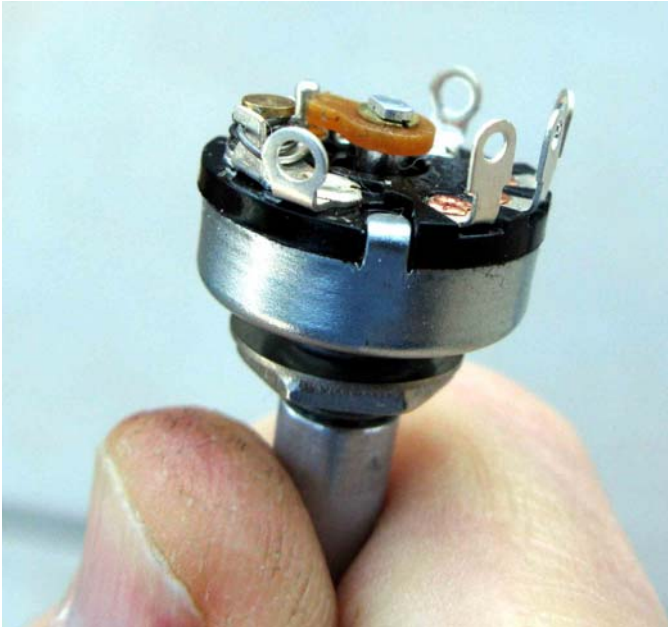

### **Testing**

Snap on a 9 volt battery or plug in a 12.0 -13.8 VDC power supply to the 2.1mm jack, J2. The center pin is positive. With the power switch "ON", you should see the power led illuminate, and should be able to see +5VDC at Vcc, pin 8 of U1 socket, and pin 6 of U2. Turn "OFF" the power, and you may now carefully insert U1 into the socket, observing that the small indentation denotes pin 1, and matching it to the silk screened dot on the pcb. Turn the power back "ON", advance the volume control, and you should be able to press the push button "FUNCTION" switch and hear the tones indicating the operation of the keyer described in the operating section. An audio input into J3 should yield amplification to the speaker. As always, if any problems are encountered, look for the most common problem, poor solder joints. Next is an incorrectly identified part, and reversed polarity components. Sometimes it is difficult to see your own mistakes, so have another person check it out.

- Next, apply the decals to the chassis as described in Appendix A.

You may now proceed to the mounting of the board to the chassis and final assembly.

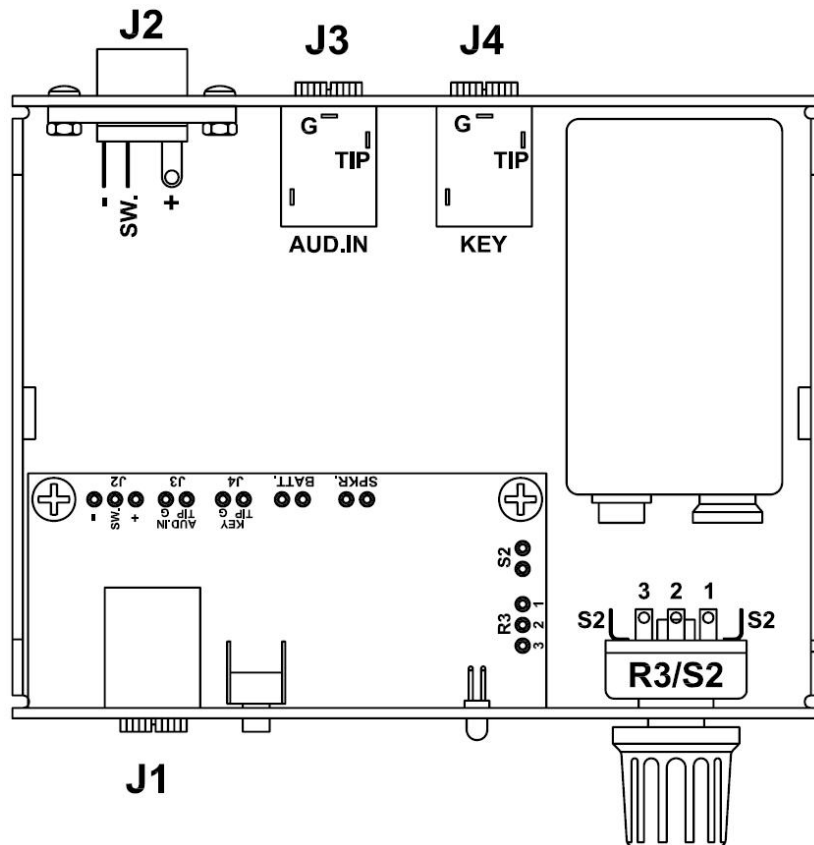

- Line up the J1 and the led to the holes in the chassis front and secure the board with threaded nut for J1 and two 4-40 x 1/4" pan head screws for the pcb.
- Secure the DC power connector with the two 2mm pan head screws and nuts.
- Mount the potentiometer and tighten the supplied nut and washer. Check to see that none of the potentiometer connections touch the bare chassis. Trim if needed.
- J2 and J3 can be secured with the threaded nuts in the proper holes provided in the rear. If a battery is used, a piece of two sided tape may be used under the battery to keep it from moving inside.
- Attach the speaker to the cover using the two clips and 4-40 x 3/8 flat head screws.
- Finally, attach the cover to the chassis base using two 4-40 x 1/4 flat head screws.
- Attach the four rubber feet, and the instrument knob.

This completes the assembly.

### **General operation notes:**

Interconnection to your device makes an assumption that the output and input to and from your device is between ground and the tip of a stereo plug. If your device uses the sleeve instead of the tip, your interconnecting cables will have to be adjusted accordingly.

If your device generates its own sidetone internally, jumper the NST pads.

If your device does not generate its own sidetone internally, do not jumper the NST pads.

Also, by removing the NST internal jumper, you can also use this kit as a code practice oscillator with your paddle. Be sure to turn off when changing jumpers.

The front paddle input connections to the keyer/speaker console are set up for the tip being "dit" and the sleeve to be "dah" on a stereo plug.

Note that the Mute and ST connections are not used. They are part of Steve's original design and were left for any flexibility.

### **Keyer Operation**

There are five possible functions which are selected using the "Function" Switch. These are:

1. Send message
2. Set code speed
3. Enter and exit Tune Mode
4. Enter store message mode
5. Change from Iambic B to A mode.

### **Sending messages:**

After a short, quick click of the function switch, tap the Dot paddle to send message 1 or tap the Dash paddle to send message 2. Once a message has started to be sent, it can be paused, stopped or set to beacon mode. Note: only message 1 can be used for beacons.

Pause: Close and hold the Dash paddle.

Stop: Close and hold the Dot paddle.

NOTE: these actions will occur after a character currently being sent has finished sending.

### **Beacon mode:**

Click and hold the function button as Message 1 is being sent. The letter “B” will sound from the side tone when the mode is activated. There is a fixed 3 second delay between repeating the message. Closing either paddle during the delay will terminate beacon mode. In addition, message Pause and Stop may be used during the sending of the message.

### **Change code speed:**

A short, quick click of the switch enters change code speed mode. There is a short pause to see if you want to send a message, then letter “S” will be sounded by the side tone.

- Closing the Dash paddle will increase the code speed, a dot will sound each time the speed is incremented by 1 wpm.
- Closing the Dot paddle will decrease the code speed. Again, a dot will sound each time the speed is decremented by 1 wpm.
  
- At the upper and lower speed limits, a double dot (I) will sound.
- The change code speed mode will automatically exit after the paddles have been released for about 1 second.

### **Tune mode:**

Tune mode is used when you want to key the transmitter continuously to say adjust an antenna tuner or make a power output measurement.

To enter Tune mode:

- Click and hold closed the function switch until the letter “T” is sounded by the side tone (about 1 second).
- To key the transmitter on, tap the Dash paddle closed.
- To turn the transmitter off, tap the Dot paddle closed.
- Repeat as needed.
- To exit Tune mode and return to normal operation, click the Function switch.

### **Entering Messages:**

- Click and hold the function switch closed until the letter “M” is sounded by the side tone, about 1 second after the tune mode annunciation of “T”.
  
- A message of up to 29 characters (including word spaces) may now be entered via the paddle. If you exceed the maximum character limit, “EM” will sound and you



## Decal Installation

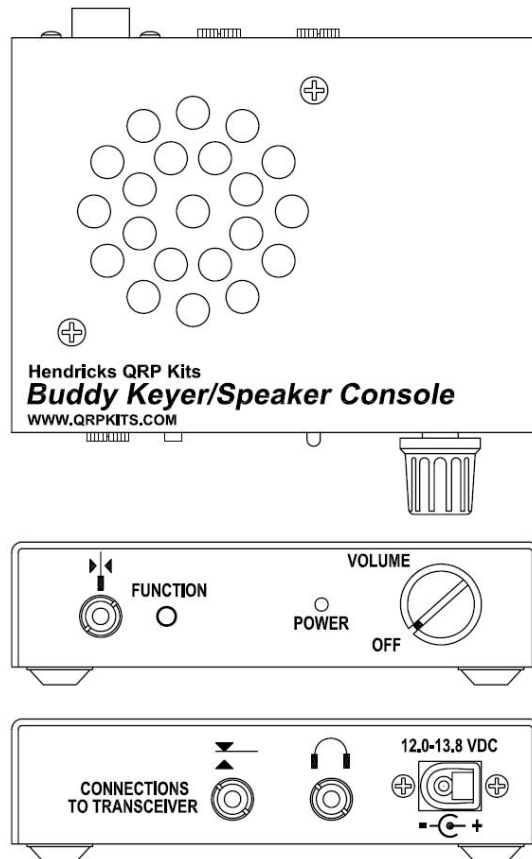

The decals are applied the same as model decals. Cut around each group of text or symbols you wish to apply. It doesn't have to be perfect as the background film is transparent. Apply the decals before you mount anything to the chassis. Use the above picture to get the correct spacing around the holes and cutouts, as it is very easy to do a great decal installation and have a portion covered up with a knob

**Thoroughly clean the surface of the panel to remove any oils or contamination. We have found that moving the decals into position on bare aluminum chassis is difficult, due to the brushed surface, so we advise pre-coating the chassis with the Krylon clear before applying the decals.**

Trim around the decal. After trimming, place the decal in a bowl of lukewarm water, with a small drop of dish soap to reduce the surface tension, for 10-15 seconds. Using tweezers, handle carefully to avoid tearing. Start to slide the decal off to the side of the backing paper, and place the unsupported edge of the decal close to the final location. Hold the edge of the decal against the panel, with your finger, and slide the paper out from under the decal. You can slide the decal around to the right position, as it will float slightly on the film of water. Use a knife point or something sharp to do this. When in position, hold the edge of the decal with your finger and gently squeegee excess water out from under the decal with a tissue or paper towel. Work from the center, to both sides. Remove any bubbles by blotting or wiping gently to the sides. Do this for each decal, and take your time. Allow to set overnight, or speed drying by placing near a fan for a few of hours. When dry, spray two **light** coats of matte finish, Krylon, clear to seal and protect the decals, and allow to dry in between coats. All decals come with two complete sets, in case you mess one up.



## Appendix C

If desired, print this, cover with packaging tape, and attach to the bottom to the chassis, as a quick reference for the keyer options. Refer to the keyer instructions mention earlier for expanded explanations.

### SKC Keyer Options

Change Keyer Speed - Hit "Function" letter "S" is sent, dit to slow, dah to speed up, after a couple of seconds, the letter "I" is sent.

Manual Tune Mode - Hold "function" until "T" is sent. Hit dah for transmit, dit to stop. Hit "Function" to return.

Store up to two 29 Char. Messages - Hold "Function" until "M" is sent. Enter message. Click "function" to hear message and check message. To re-enter message click "Function", "EM" will be sent. Enter message again. To store, tap dit for message location #1, dah for location #2.

Send Message - Hit "function briefly, dit to send message #1, dah to send message #2.