

## Hendricks 41dB Step RF Attenuator



- First, familiarize yourself with the parts and check for all the components.

### Parts Inventory

R1 – 6.2 ohm, 2W, resistor (blue-brown-gold-gold)  
R4 – 12 ohm, 2W, resistor (brown-red-black-gold)  
R7 – 18 ohm, 2W, resistor (brown-gray-black-gold)  
R10 – 33 ohm, 2W, resistor (orange-orange-black-gold)  
R17 & R18 – 68 ohm, 2W, resistor (blue-gray-black-gold)  
R13 – 75 ohm, 2W, resistor (violet-green-black-gold)  
R14 & R15 – 100 ohm, 2W, resistor (brown-black-brown-gold)  
R11 & R12 – 200 ohm, 2W, resistor (red-black-brown-gold)  
R16 – 270 ohm, 2W, resistor (brown-violet-brown-gold)  
R8 & R9 – 300 ohm, 2W, resistor (orange-black-brown-gold)  
R5 & R6 – 470 ohm, 2W, resistor (yellow-violet-brown-gold)  
R2 & R3 – 910 ohm, 2W, resistor (white-brown-brown-gold)  
7 – DPDT slide switches  
2 – BNC female chassis connectors  
4 - 4-40 x 1/4" undercut Philips flat head screw  
6 - 4-40 x 1/4" Philips head screw  
4 – rubber feet  
1 – decal set  
1 – aluminum chassis  
12" – Teflon hook-up wire

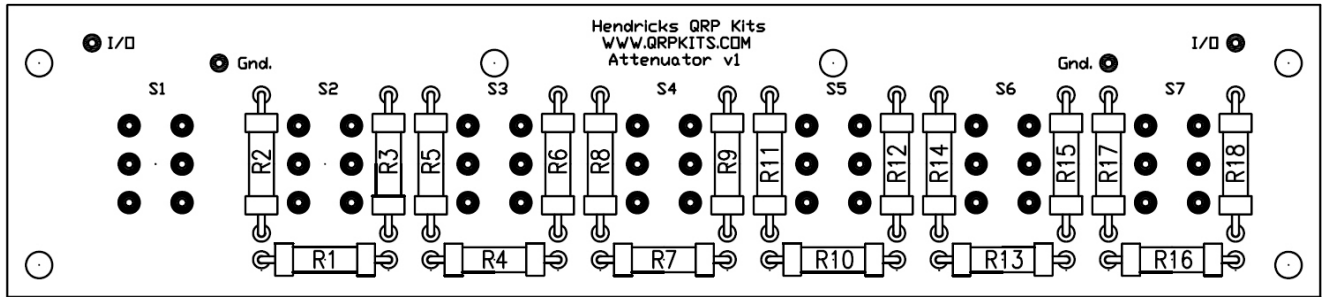

Begin by installing resistors R1 thru R18 on the side of the board with the silk screening.

**Note: These 2 watt resistors have color codes that are difficult to read, due the texture and color of the resistor. It is best to check the value before installing and soldering. They can be difficult to exchange.**

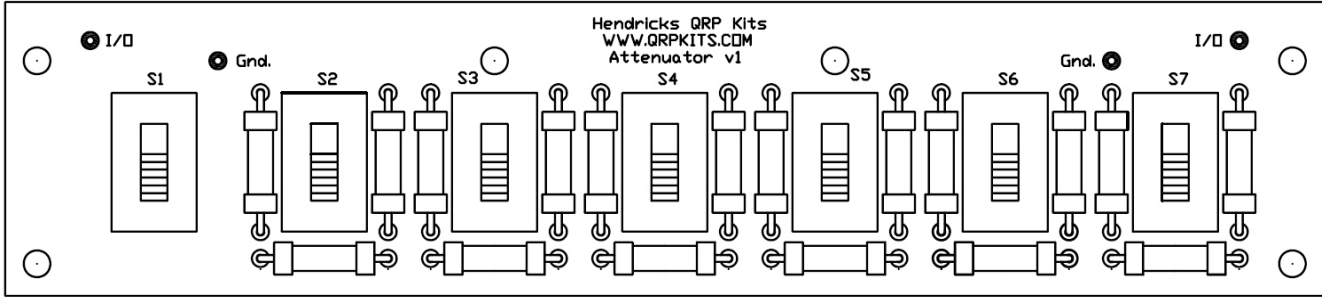

Next, install the DPDT slide switches, S1 thru S7 on the same side as the resistors.

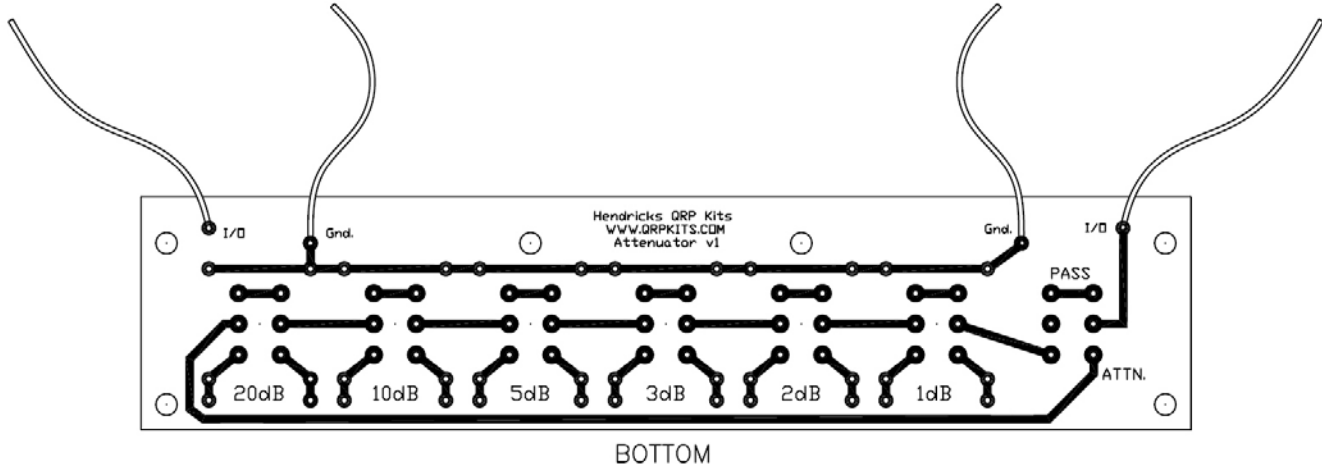

Turn the board over (switches down) and cut 2" long pieces of the supplied wire. Strip, tin, and solder to the I/O and Gnd. pads on the bottom of the board as shown. This completes the pcb assembly.

## Testing:

Lets test the board before we proceed to the final assembly. If you put the resistors in the proper position, you should get similar values to our check we made with a digital ohm meter at the different switch settings. Hook up your ohm meter to either end of the attenuator I/O and Gnd. Place all the switches up into "Bypass" and the resistance should be infinite. Place the first switch into the "ATTN" position, then switch in and out of "Attenuate" each switch separately, to see if you get similar readings. The readings may not be exact, as the resistors are 5% tolerance, and your test lead resistance may be a little different than mine, but it will give you an idea if you inadvertently swapped a value.

1 dB - 456 ohms  
2 dB - 235 ohms  
3 dB - 153 ohms  
5 dB - 107 ohms  
10 dB - 64 ohms  
20 dB - 57 ohms

## Chassis preparation:

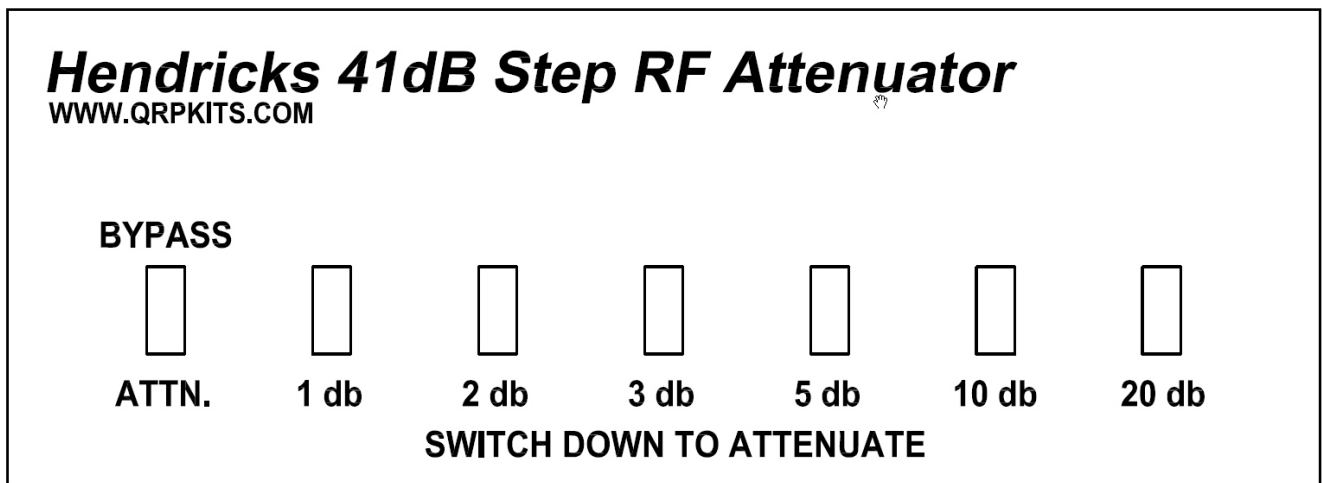

**Thoroughly clean the surface of the panel to remove any oils or contamination. If you do not paint your case, we have found that moving the decals into position on a bare aluminum chassis is more difficult, due to the brushed surface, so we advise pre-coating the chassis with a light coating of the Krylon clear before applying the decals.**

The decals are applied the same as model decals. Cut around each group of text you wish to apply. It doesn't have to be perfect as the background film is transparent. Apply the decals before you mount anything to the chassis. Use the above picture to get the correct spacing around the holes

Trim around the decal. After trimming, place the decal in a bowl of lukewarm water, with a small drop of dish soap to reduce the surface tension, for 10-15 seconds. Using tweezers, handle carefully to avoid tearing. Start to slide the decal off to the side of the backing paper, and place the unsupported edge of the decal close to the final location. Hold the edge of the decal against the panel, with your finger, and slide the paper out from under the decal. You can slide the decal around to the right

position, as it will float slightly on the film of water. Use a knife point or something sharp to do this. When in position, hold the edge of the decal with your finger and gently squeegee excess water out from under the decal with a tissue or paper towel. Work from the center, to both sides. Remove any bubbles by blotting or wiping gently to the sides. Do this for each decal, and take your time. Allow to set overnight, or speed drying by placing near a fan for a few of hours. When dry, spray two **light** coats of matte finish, Krylon, clear to seal and protect the decals, and allow the spray to dry in between coats. All decals come with two complete sets, in case you mess one up.

- **Final Assembly:**

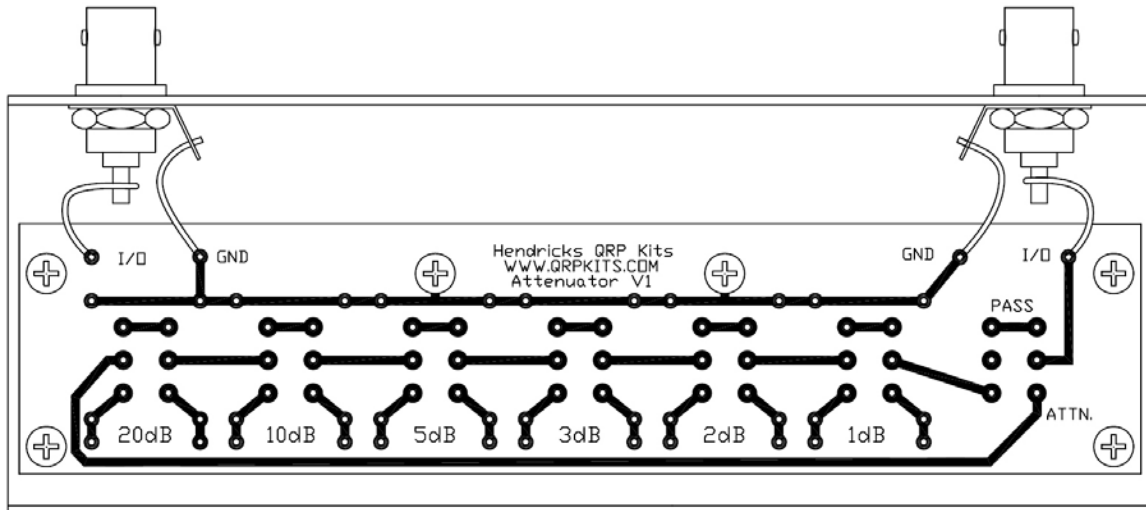

- Install the two BNC connectors with the ground tabs turned, as shown above.
- Install the finished pcb into the chassis cover as shown, using the six 4-40 philips pan head screws.
- Strip, tin, and solder the I/O and Gnd. wires as shown.

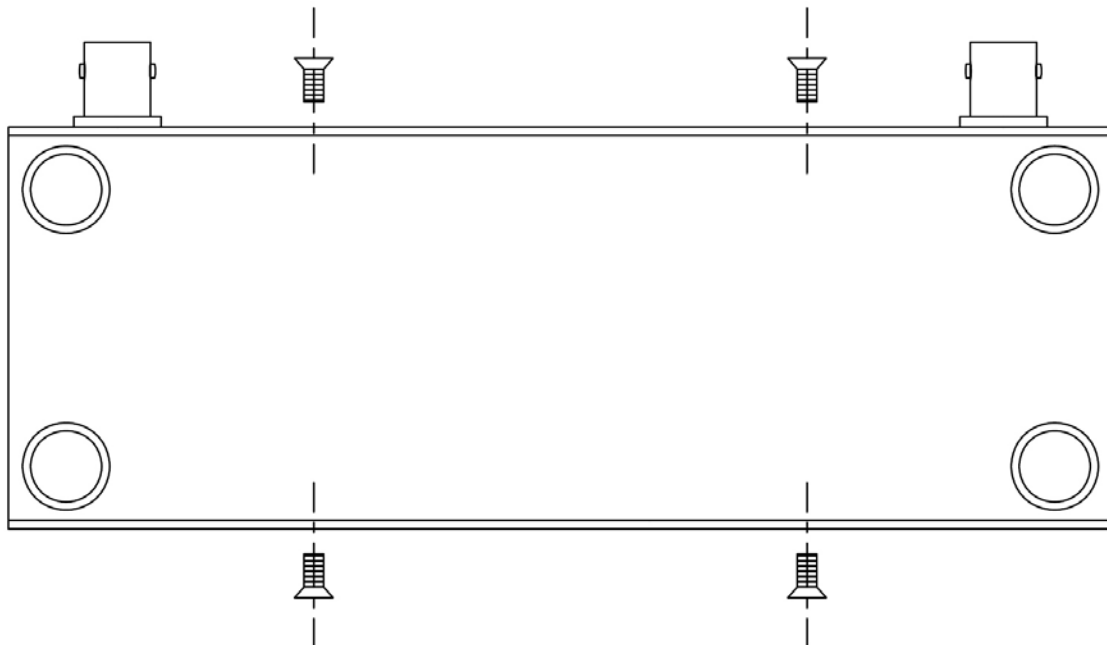

- Fit the bottom cover onto the chassis and secure with the four flat head 4-40 philips screws.
- Attach the four rubber feet on the bottom corners.

## Using your Hendricks 41dB Step Rf Attenuator

The attenuator is bidirectional, either end can be an input or output. The attenuator can be taken completely out of the circuit, by switching to "Bypass".

We designed this device to used on the HF bands up to 30MHz, our testing with an Agilent Network Analyzer PNA E8357A produced these values shown at 7030 kHz.

dB Setting	Percent of Signal	Output W with 5 Watt Input	Output W with 1 Watt Input
Bypass	99.77	4.9885	.9977
-1	77.62	3.8810	.7762
-2	62.52	3.1265	.6252
-3	49.32	2.4660	.4932
-4	38.99	1.9495	.3899
-5	31.48	1.5740	.3148
-6	24.89	1.2445	.2489
-7	19.95	.9975	.1995
-8	15.74	.7875	.1574
-9	12.47	.6235	.1247
-10	9.68	.4840	.0968 (96.8 mW)
-15	3.10	.1550 (155 mW)	.0310 (31.0 mW)
-20	1.03	.0515 (51.5 mW)	.0103 (10.3 mW)
-25	.33	.0150 (15.0 mW)	.0033 (3.3 mW)
-30	.11	.0055 (5.5 mW)	.0011 (1.1 mW)
-35	.04	.0020 (2.0 mW)	.0004 (400 uW)
-40	.02	.0010 (1.0 mW)	.0002 (200 uW)

Theoretical dB to percent signal calculator can be found here:

<http://www.lumonics.com/percent-to-dB-conversion-calculator.php>

If you like, scale your printer to print this out to the dimensions shown, seal with some packaging tape, and apply it to the bottom of the chassis, with some two sided tape for future reference.

4 1/4"

ATTENUATION GUIDE AT 7030 kHz			
dB Setting	Percent of Signal	Output with 5 Watt Input	Output with 1 Watt Input
-1	77.62	3.8810	.7762
-2	62.52	3.1265	.6252
-3	49.32	2.4660	.4932
-4	38.99	1.9495	.3899
-5	31.48	1.5740	.3148
-6	24.89	1.2445	.2489
-7	19.95	.9975	.1995
-8	15.74	.7875	.1574
-9	12.47	.6235	.1247
-10	9.68	.4840	.0968 (96.8 mW)
-15	3.10	.1550 (155 mW)	.0310 (31 mW)
-20	1.00	.0515 (52 mW)	.0103 (10.3 mW)
-25	.33	.0150 (15 mW)	.0033 (3.3 mW)
-30	.11	.0055 (5.5 mW)	.0011 (1.1 mW)
-35	.04	.0020 (2.0 mW)	.0004 (400 uW)
-40	.02	.0010 (1.0 mW)	.0002 (200uW)

2"

**Schematic:**

