

# Pacific Antenna 10 Watt HF Amplifier Kit

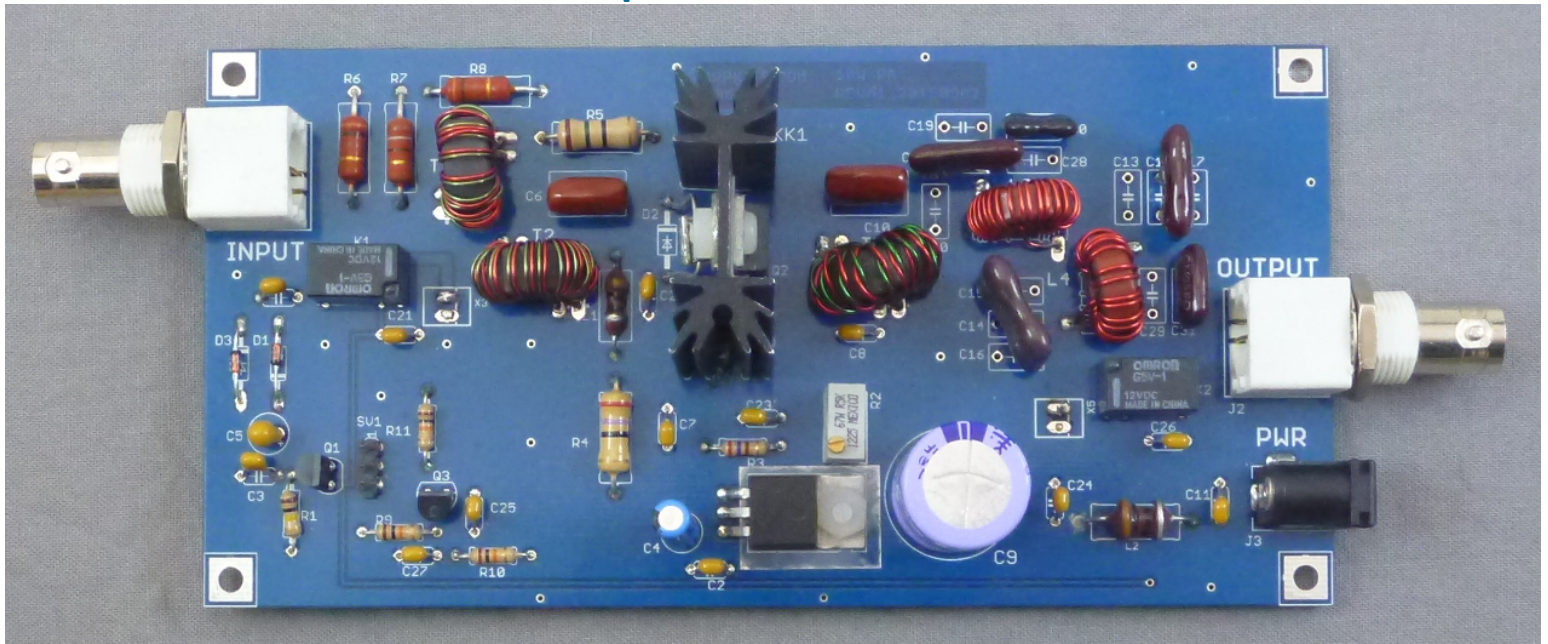

## Description

Our 10 watt Linear, HF amplifier kit provides up to 20dB gain utilizing a 2SC1969 transistor.

Resistive attenuation network configurable for transmitters from 100 mW to approximately 3W.

Automatic, RF sensed, TR switching.

Can be remotely keyed and locked out if needed by grounding one of two control lines.

Diode controlled temperature feedback for stability.

Operates from 11-14Vdc

Provides stable, linear operation for CW, SSB and Digital applications.

## Support

PACIFIC ANTENNA

QRP KITS.COM

[qrpkits.com@gmail.com](mailto:qrpkits.com@gmail.com)

## Tools Needed

- ❑ Temperature Controlled Soldering Station with small tip or 15-35 watt soldering iron with small tip.
- ❑ Solder, 60/40 or 63/37 Tin-Lead recommended
- ❑ Small Diagonal Cutters
- ❑ Small Needle Nose Pliers
- ❑ Pencil, Pen, and/or Highlighter
- ❑ BRIGHT work light
- ❑ Meter to measure current (typical DMM will be ok)
- ❑ 50 Ohm Dummy load capable of handling 10W

## Optional

- ❑ Watt meter to measure output of amplifier.
- ❑ Magnifying headpiece or lighted magnifying glass.
- ❑ Solder Sucker or Solder Wick
- ❑ Small multi-blade Screw Driver
- ❑ Knife or Wire Stripper
- ❑ Small Ruler
- ❑ Cookie Sheet to build in and keep parts from jumping onto the floor.

## Construction Techniques

- ❑ There is no need to print out the whole assembly manual unless you want a copy. Print the Parts List and Schematic (last two pages) then view the rest of the manual on a computer, laptop, or tablet.
- ❑ The Parts List has columns for inventory and construction.
  - Use the first column to check the parts as you inventory them.
  - Use the second column to check the parts as you install them.
- ❑ Please take time to inventory the parts before starting. Report any shortages to QRPKITS.com (In many cases it may be faster and cheaper to pull a replacement from your parts supply, but please let us know if we missed something.)
- ❑ Pre-sorting components can speed up the assembly and reduce mistakes.
- ❑ If you are a beginner, new to soldering, there are a number of resources on the web to help you get on the right track soldering like a pro. Google Soldering Techniques.
- ❑ Use a Temperature Controlled Soldering Station with small tip or 15-35 watt soldering iron with small tip. Conical or very small screw driver tips are best. DO NOT use a large soldering iron or soldering gun.
- ❑ You can insert several parts at a time onto the board. When you insert a part bend the leads over slightly to hold the part in place, then solder all at the same time. Clip the leads flush.
- ❑ Most parts should be mounted as close to the board as possible. Transistors should be mounted about 1/8" above the board. Solder one lead on ICs or IC sockets and then check to make sure the component is flush before soldering the remaining leads.

## 10 Watt HF Amplifier Inventory and Parts List

Inventory	Installed	Quan.	Part #	Value	Identification	Description
		1	R3	270 Ω	red-vio-brn-gold	Resistor ¼ W
		3	R9, R10, R11	10K Ω	brn-blk-org-gold	Resistor ¼ W
		1	R1	100K Ω	Brn-blk-yel-gold	Resistor ¼ W
		1	R5	15 Ω	Brn-grn-blk-gold	Resistor 1 W
		1	R4	27 Ω	Red-vio-blk-gold	Resistor 1 W
		1	C1	100pF	101	Disk Ceramic Capacitor
		12	C2, C3, C7, C8, C11, C21, C22, C23, C24, C25, C26, C27	0.1uF	104 (yellow)	Capacitor, monolythic
		2	C6, C10	0.1uF	104K (red)	Film Capacitor
		1	C5	4.7uF	4.7 uF	Tantalum Capacitor
		1	C4	10uF	10 uF	Electrolytic Capacitor
		1	C9	1000uF	1000 uF	Electrolytic Capacitor
		1	L1	10uH	Brn-blk-blk-silver	Inductor small
		1	L2	10uH	Brn-blk-blk-silver	Inductor Large
		2	D1, D3	1N4148	Glass Diode	Diode
		1	Q1	BS170	BS 170	Mosfet, TO-92
		1	Q3	2N3906		PNP Transistor, TO-92
		1	R2	5K Ω	R5K	5K Ω 10 turn trimmer
		2	K1, K2	G5V1	G5V1	Relay, black, 6 pin
		1	Q2	2SC1969	2SC1969	Transistor, TO-220
		1	IC1	LM-317	LM317MABT	Voltage Reg. TO-220
		2	INS	Insulator	Mica Insulator	Insulator for TO-220
		2	Screw	4-40	4-40x 1/4" screw	Nylon 4-40 screw
		2	Nut	4-40	4-40 nut	Nylon 4-40 nut
		1	KK1	Heatsink	Black	Finned Heatsink
		2	D2	Diode	1N4004, plastic diode	Diode to mount on heatsink
		2	RT	Terminal	crimp terminal	Flag Ring Terminal for diode
		3	T1, T2, T3	FT50-43	Toroids, shiny gray	4:1 bifiliar winding
		1	4 feet	#26 wire	Green magnet wire	#26 Green wire for T1,T2 and T3
		1	4 feet	#26 wire	Red magnet wire	#26 Red wire for T1, T2, and T3
		1	SV1	3 Pin	Header strip	3 pin snappable header strip
		1	J3	Power Jack	Black coax power jack	PCB MOUNT 2.1mm Jack
		2	J1, J2	BNC Jack	Black, 90 degree BNC	Board mount BNC Jack
		6"	COAX	RG174	Small black coax	RG174 coax cable
		1	PCB	PCB	Circuit Board	10W AMP PCB
		1	Thermal grease	Tube	syringe tube	Thermal Grease Syringe
		1	R7	18Ω 2W	Brn-gry-blk-gold	Resistor 2 W, attenuator, 3dB
		2	R6, R8	300Ω 2W	Org-blk-brn-gold	Resistor 2 W, attenuator, 3dB
		1	R7	39Ω 2W	Org-wht-blk-gold	Resistor 2 W, attenuator, 6dB
		2	R6, R8	150Ω 2W	Brn-grn-brn-gold	Resistor 2 W, attenuator, 6dB
		1	R7	75Ω 2W	Vio-grn-blk-gold	Resistor 2 W, attenuator, 10dB
		2	R6, R8	100 Ω 2W	Brn-blk-brn-gold	Resistor 2 W, attenuator, 10dB

**Note:** Band kits of capacitors, toroids and wire are in separate packages and are listed in the table on page 10.

**Note:** the kit includes a small container of heat sink grease. This should be used on Q2 and IC1 (the TO220 parts) to provide better cooling. It should also be used on the ring terminal used to hold Diode D2.

# 10W HF Amplifier Parts Identification

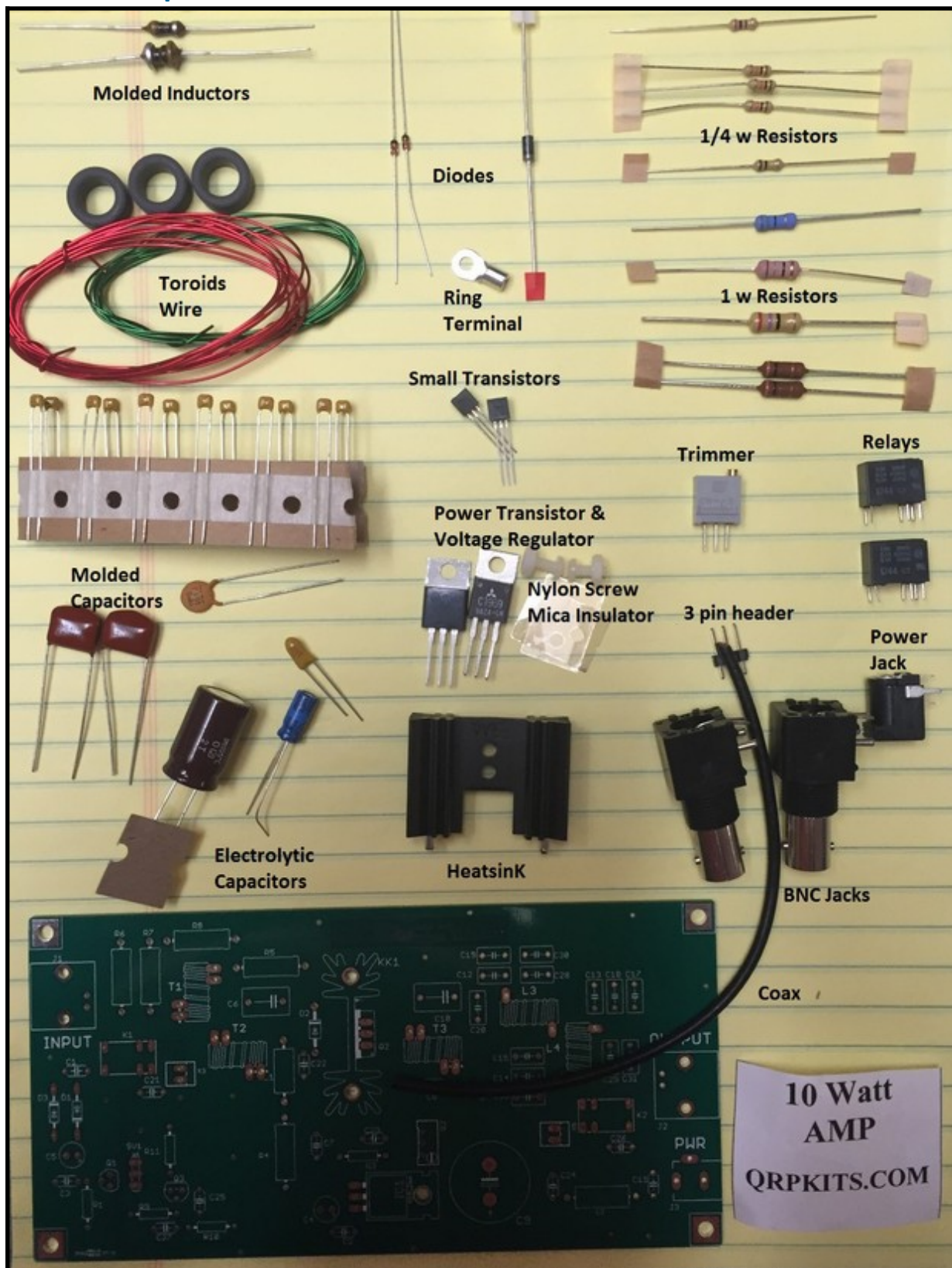

# Board Layout

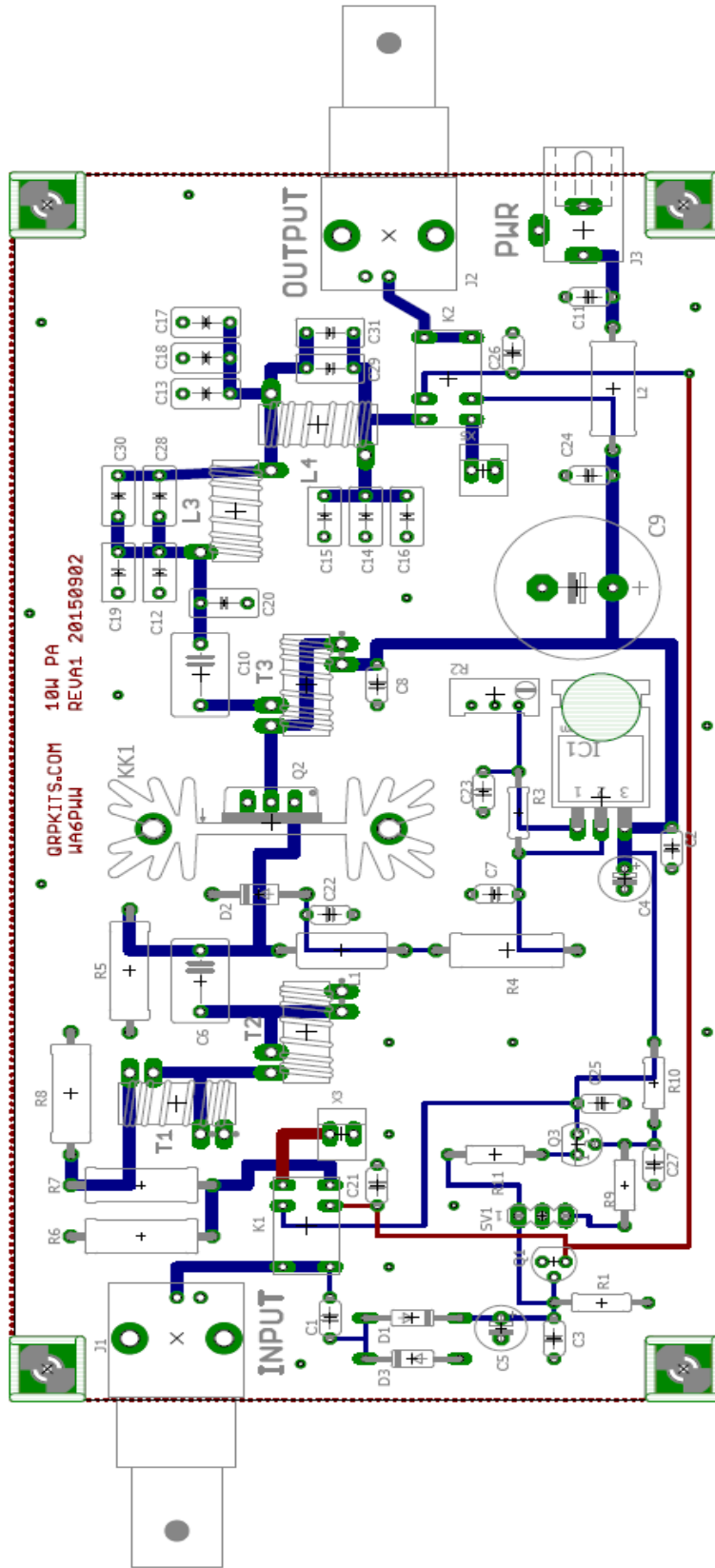

## Inserting the Parts

### Resistors

Sort the resistors by value insert them smallest value first, largest value last. Be sure to check the color code for each resistor as you install. [Measuring with an Ohm meter is a good idea.]

<input type="checkbox"/>	1	R3	270 $\Omega$	red-vio-brn-gold	Resistor, 1/4w
<input type="checkbox"/>	1	R9	10K $\Omega$	brn-blk-org-gold	Resistor, 1/4w
<input type="checkbox"/>	1	R10	10K $\Omega$	brn-blk-org-gold	Resistor, 1/4w
<input type="checkbox"/>	1	R11	10K $\Omega$	brn-blk-org-gold	Resistor, 1/4w
<input type="checkbox"/>	1	R1	100K $\Omega$	brn-blk-yel-gold	Resistor, 1/4w
<input type="checkbox"/>	1	R5	15 $\Omega$	brn-grn-blk-gold	Resistor, 1W
<input type="checkbox"/>	1	R4	27 $\Omega$	red-vio-blk-gold	Resistor, 2W
<input type="checkbox"/>	1	R6	*	See Attenuator table	Resistor, 2W
<input type="checkbox"/>	1	R7	*	See Attenuator table	Resistor, 2W
<input type="checkbox"/>	1	R8"	*	See Attenuator table	Resistor, 2W
<input type="checkbox"/>					

Note: See input attenuator table for R6,R7 and R8 values. The kit will be supplied with resistors for 3dB, 6dB and 10dBattenuation levels. You should select the values based on your transmitter output to give approximately 200-500mW drive to the amplifier.

### Capacitors

insert the molded capacitors.

<input type="checkbox"/>	1	C1	100pF	101	Disk ceramic capacitor
<input type="checkbox"/>	1	C2	0.1uF	104 (YEL)	Capacitor, monolithic
<input type="checkbox"/>	1	C3	0.1uF	104 (YEL)	Capacitor, monolithic
<input type="checkbox"/>	1	C7	0.1uF	104 (YEL)	Capacitor, monolithic
<input type="checkbox"/>	1	C8	0.1uF	104 (YEL)	Capacitor, monolithic
<input type="checkbox"/>	1	C11	0.1uF	104 (YEL)	Capacitor, monolithic
<input type="checkbox"/>	1	C21	0.1uF	104 (YEL)	Capacitor, monolithic
<input type="checkbox"/>	1	C22	0.1uF	104 (YEL)	Capacitor, monolithic
<input type="checkbox"/>	1	C23	0.1uF	104 (YEL)	Capacitor, monolithic
<input type="checkbox"/>	1	C24	0.1uF	104 (YEL)	Capacitor, monolithic
<input type="checkbox"/>	1	C25	0.1uF	104 (YEL)	Capacitor, monolithic
<input type="checkbox"/>	1	C26	0.1uF	104 (YEL)	Capacitor, monolithic
<input type="checkbox"/>	1	C27	0.1uF	104 (YEL)	Capacitor, monolithic
<input type="checkbox"/>	1	C6	0.1uF	104K (RED)	Film Capacitor (Red)
<input type="checkbox"/>	1	C10	0.1uF	104K (RED)	Film Capacitor (Red)

**Note:** the bandkit capacitors are not included in this list

## Electrolytics

Now insert the tantalum capacitor and electrolytic capacitors. These capacitors are polarized. The longer lead is the positive + (plus) lead. The positive hole is marked on the circuit board with a + symbol. The shorter lead is the - (minus) lead. The negative lead is also marked with a black bar on the side of the capacitor.

<input type="checkbox"/>	1	C5	4.7uF	4.7	Tantalum Capacitor
<input type="checkbox"/>	1	C4	10uF	10 uF	Electrolytic Capacitor
<input type="checkbox"/>	1	C9	1000uF	1000 uF	Electrolytic Capacitor

## Molded Inductors

<input type="checkbox"/>	1	L1	10uH	brn-blk-blk-silver	Molded inductor, small
<input type="checkbox"/>	1	L2	10uH	brn-blk-blk-silver	Molded inductor, large

## Remaining small parts

<input type="checkbox"/>	1	D1	1N4148	4148 (glass)	DIODE
<input type="checkbox"/>	1	D3	1N4148	4148 (glass)	DIODE
<input type="checkbox"/>	1	Q1	BS170	BS170	N-CHANNEL Mosfet
<input type="checkbox"/>	1	Q3	2N3906	2N3906	PNP Transistor
<input type="checkbox"/>	1	R2	5K	R5K	Trimmer gray multi turn
<input type="checkbox"/>	1	K1	G5V1	G5V1	RELAY
<input type="checkbox"/>	1	K2	G5V1	G5V1	RELAY

**Note:** Trimmer R2 should be installed as shown by the board silkscreen and on the layout on P5. The adjustment screw will be down on the side next to IC1 and C9. If it is installed backwards, it will still work but adjustment direction *will* be reversed.

The LM317 regulator is mounted to the board using a mica insulator and the a Nylon Screw & Nut. Bend the leads carefully and test fit to the boards. Make sure the tab lies flat and then apply a small amount of heat sink compound to the regulator tab and to the board, place the insulator in place and attach the LM317 using the nylon screw and nut. DO NOT SOLDER the leads until the screw is tight.

<input type="checkbox"/>	1	IC1	LM317	Voltage Regulator
<input type="checkbox"/>	1	INS	Mica Insulator	TO-220 Mica insulator
<input type="checkbox"/>	1	SCREW	Nylon Screw	#4-40 x 1/4" Nylon
<input type="checkbox"/>	1	NUT	Nylon Nut	#4-40 Nylon Nut

## Parts on the Heatsink

First, solder the heatsink to the board using the 2 large pins. This may require a larger soldering iron or at least operating on the highest temperature setting for small irons.

Solder one pin and check that the insulator is flush with the board and vertically straight before soldering the second pin.

<input type="checkbox"/>	1	screw	Nylon Screw	#4-40 x 1/4" #4-40 x 1/4" Nylon
<input type="checkbox"/>	1	nut	Nylon Nut	#4-40 #4-40 Nylon Nuts
<input type="checkbox"/>	1	KK1	Heatsink	Black finned with PCB pins
<input type="checkbox"/>	1	D2	1N4004	DIODE
<input type="checkbox"/>	1	RT	Ring Terminal	Flag Ring terminal
<input type="checkbox"/>	1	Q2	2SC1969/MRF475	NPN RF Power Transistor
<input type="checkbox"/>	1	INS	Mica Insulator	TO-220 Mica insulator

## Preparing D2:

Diode D2 is used as temperature feedback for the bias current regulator to control thermal drift in the amplifier bias. D2 is mounted, using a flag ring terminal that is supplied in the kit so that it can be attached to the back side of the heatsink for Q2.

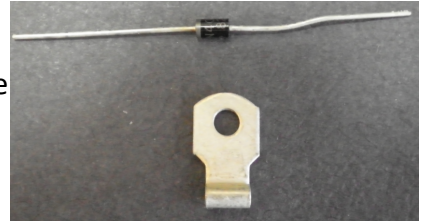

Using needle nose pliers or screwdrivers, open the wire crimp section of the ring terminal to make a u shaped space for the 1n4004 diode body to fit into the ring terminal.

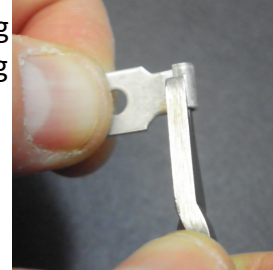

The ring terminal should fit into the u shaped area formed by opening up the crimp area on the ring terminal. Before crimping down, apply a small amount of heat sink compound to the diode body.

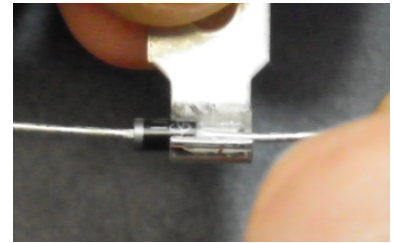

Carefully and gently close the u shaped opening around the diode, making sure band is on the left as shown in the picture above.



Be careful not to crush the diode. Just in case, a spare diode and ring terminal are included in the kit.

Carefully bend the leads of the diode so that they will reach down to the board when the diode is attached to the heatsink. Be careful to keep the leads from shorting to the ring terminal.



Insert their respective leads into the board and mount the ring terminal to the side of the heatsink closest to the diode drawing on the and Q2 to the opposite side using the same nylon screw and nut that hold Q2 to the other side of the heatsink.

A mica insulator is placed between Q2 and the heatsink to provide electrical isolation.

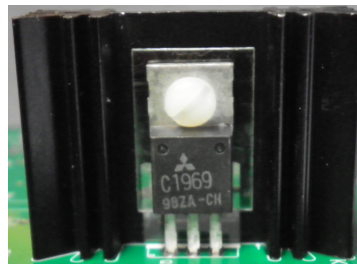

A thin film of heat sink compound should be used on the tab of Q2 and the heatsink to provide good thermal contact.

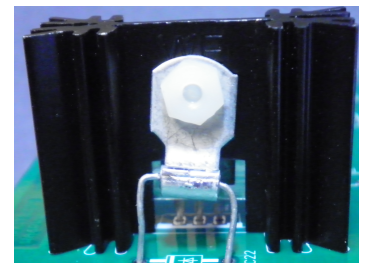



When both parts are in place, tighten the screw to hold Q2 and the ring terminal holding diode D2 in contact with the heat sink.

Once everything is in place and the screw is tight, solder the leads for the transistor and diode D2 to the board.

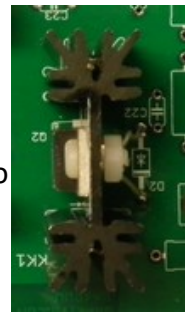

## Toroids

□ 1	T1	FT50-43 Toroids	16 Turns 4:1 Bifiliar on FT50-43
□ 1	T2	FT50-43 Toroids	16 Turns 4:1 Bifiliar on FT50-43
□ 1	T3	FT50-43 Toroids	16 Turns 4:1 Bifiliar on FT50-43
□ 1	L3	T50 Toroids	See Band Kit table for info
□ 1	L4	T50 Toroid	See Band Kit table for info
□ 3'	#22	RED Magnet Wire	Larger Wire for winding L3 and L4 (see band kit)
□ 4'	#26	GREEN Magnet Wire	Green wire for winding T1, T2 and T3
□ 4'	#26	RED Magnet Wire	Red wire for winding T1, T2 and T3

T1, T2 and T3 are each wound with 16 turns of parallel red and green #26 wire. This will produce a bifiliar transformer with 4 leads.

Twisting the red and green wire pairs will make winding a bit easier but is not absolutely necessary.

When wound correctly, at each end, there will be a red and a green pair of wires as shown in the photo.

**Note:** To make winding of T1, T2 and T3 easier, it is recommended to pre cut sections of the red and green #26 wire to approximately 14" long. This will be sufficient length to wind the toroids and easier to handle than using the full length of wire.



When winding, each time the wire passes through the toroid center counts as a turn. For example, just passing a wire from one side to the other of the toroid counts as a turn even though, it does not wrap around the toroid. When completed, it should look like the photo on the right.

This is a good example of the process for winding toroids: [http://www.genesisradio.com.au/help/toroid\\_winding.html](http://www.genesisradio.com.au/help/toroid_winding.html)

The wires should be stripped and tinned on the ends. The kit uses heat strippable wire so this can be done with a blob of solder on the tip of a soldering iron. Moving the blow slowly from the end of the wire will melt the insulation and tin the wire in one step. Strip and tin the wire up to the outer edge of the body of the toroid.

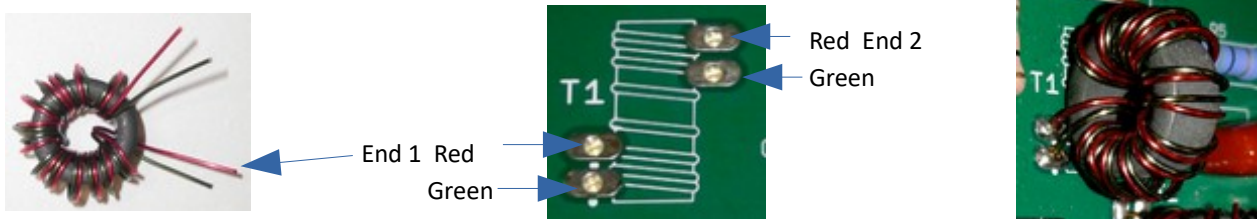

For installation, the wires are installed in sequence. It does not matter if you start with red or green but they are inserted in the board alternating colors starting with the red green pair at one end of the winding and going to the other end. Starting from the lower left pad on T1 as shown above a sequence would be: green1-red1----green2- red2

The drawings above show starting with the green wire first, but it could also start with the red wire as long as they go into the pads alternating in colors. In this case the sequence would be: red1- green1----red2- green2

Check the order of the wires then gently pull the slack from the wires and solder the wires to the board pads.

## Band Kits

Specific capacitors and toroid inductors for the filters required for the chosen band are listed in the table below.

These are high voltage ceramic capacitors and are usually marked as described in Appendix 2.

Inventory	Installed	Part #	10M +12M	15M +17M	20M	30M	40M	80
		C12, C19 or C20	TBD	TBD	180pF	270pF	390pF	1000pF
		C14, C15, or C16			180pF	270pF	390pF	1000pF
		C13, C17 or C18			2x 180pF	2x 270pF	2x 390pF	1800pF
		C28			10pF	33pF	47pF	100pF
		C30			10pF	N/A	N/A	N/A
		C29			47pf	47pF	120pF	270pF
		C31			N/A	47pF	N/A	N/A
		L3**	T50-6	T50-6	T50-2 11 turns	T50-2 12 turns	T50-2 15 turns	T50-2 17 turns
		L4**	T50-6	T50-6	T50-2 10 turns	T50-2 11 turns	T50-2 14 turns	T50-2 16 turns
					#22 Red 3ft	#22 Red 3ft	#22 Red 3ft	#22 Red 3ft

Notes:

\*In some cases, the capacitor value needed may require 2 or more smaller capacitors in parallel.

Multiple positions are included on the board to accommodate capacitors in parallel.

\*\*L3 and L4 are wound with the specified turns of #22 wire. Once wound, strip and tin the ends of the leads, then insert and solder them to the board.

## Resistive Attenuator Values

You will need to select a value of resistors that gives the desired attenuation level from the table below.

For full output, select the attenuation level that will give in the range of approximately 300 mW to 500mW drive to the amplifier from your transmitter.

For continuous modes such as digital, it is recommended to set the drive to the lower end of this range.

The gain is highest at lowest frequencies and decreases slightly as frequency goes up.

Note that the attenuator only affects the input power as it is bypassed on receive.

R6	R7	R8	Attenuation
300	18	300	3db
150	39	150	6db
100	75	100	10db

3db = 50% reduction: 1W in = 500mW to amplifier

6dB = 75% reduction: 1W in = 250mW to amplifier

10dB = 90% reduction: 1W in = 100mW to amplifier

These resistors for each of the 3 attenuation levels are included in the kit

## Final Assembly

To complete the amplifier board, install a section of coax cable between pads X3 and X5. Note the coax center goes to the upper pads when you are looking at the board from above and the shield goes to the lower pads. The pads not connected to a trace are ground (shield connection). This is recommended to be installed on the bottom of the board. This section serves to bypass the amplifier when receiving or when it is not powered.



## Connectors:

**NOTE:** If you plan to install the kit into a case, you will want to wait to install the BNC connectors so that they can be inserted through the case walls before soldering.

Alternatively, panel mount connectors for input, output and power can be used instead of the board mounted ones supplied with the kit. This allows a wide range of cases to be used.

## Setup and Testing

Once the amplifier is assembled, inspect all solder joints checking for good connections and especially, look for any solder bridges or whiskers that may short nearby pads.

Before connecting power, check with a DMM in resistance mode to verify no shorts of the center pin of each BNC to ground.

Also check from the center of the input to the output BNC connectors. This should be very low resistance, typically less than 0.5 ohms.

When first connecting power, it is best to use a power supply with current control or if that is not available, use a 5A or less fuse in the power line to protect the circuitry in case of shorts.

Carefully verify the voltages at the checkpoints shown below using a DC voltmeter. If all are ok, proceed to the next section. If not, check components and solder connections to locate any problems.

## Voltage Checkpoints

**Vin = 12.4V**

Bias pot R2 fully counterclockwise

Current draw = ~30mA

Voltages measured with respect to board ground

**Note:** Voltages will vary with input voltage

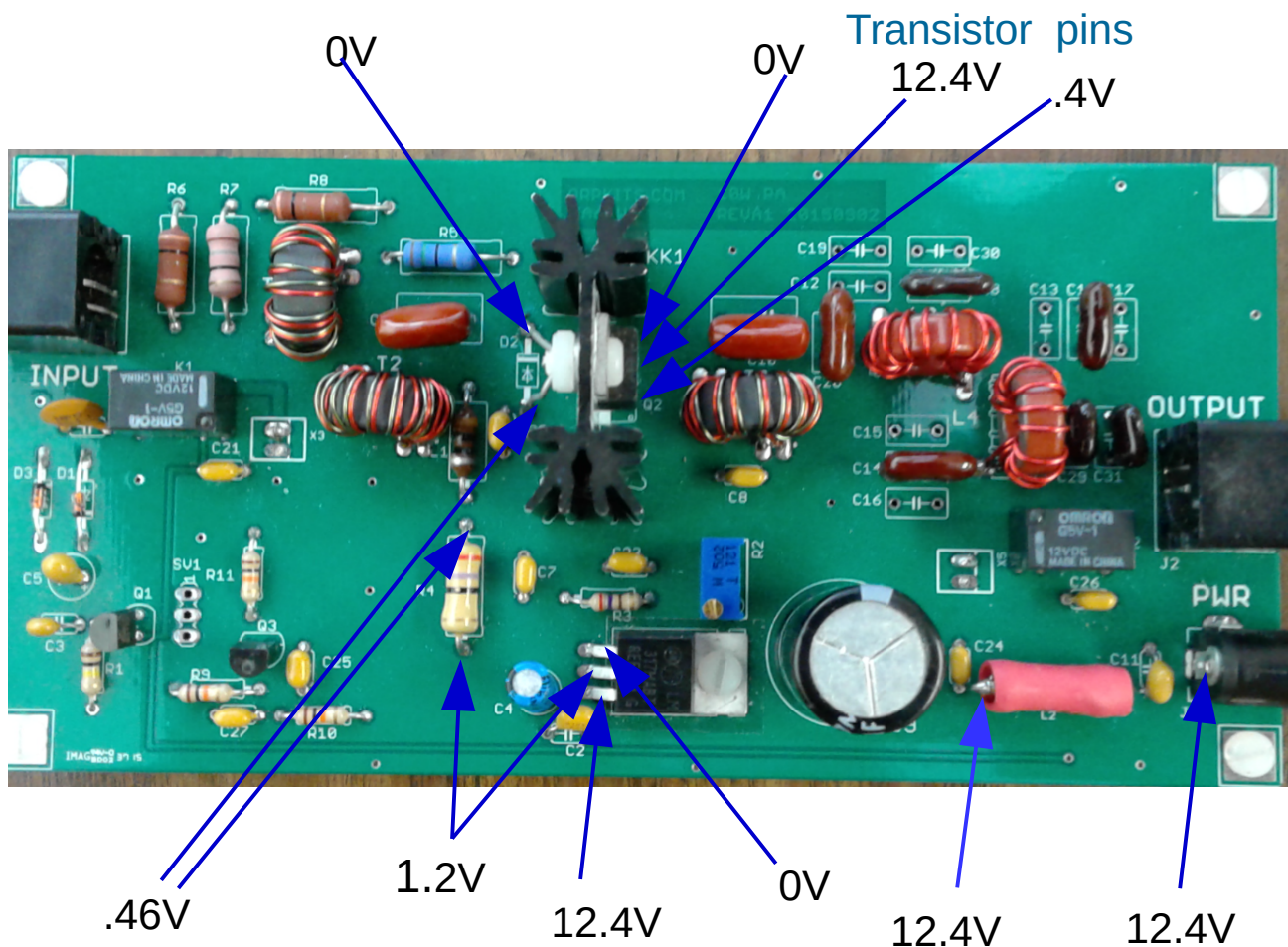

## Setting Bias Current

In order for the amplifier to operate in a linear mode, bias current is applied to slightly turn on the final transistor. The bias current is set using the trim pot R2.

To set the bias, use a multimeter in current measurement mode, placed in series with the positive lead of the DC power.

If you have a power supply with an internal current meter it may be used instead of the multimeter.

- Turn the 10 turn trim pot R2 fully counter clockwise. This may take several turns and there is no stop but you should hear it click as rotated when it is at the end of its range.
- Connect a dummy load or other 50 ohm load to the output
- Connect DC power to the amplifier.



Ground this pad (3) to  
key the amp.

- Key the amplifier using the key input on SV1 PIN 3. (connect Pin3 to ground to key)
- The current drawn by the amplifier will typically be in the range of 45-75mA
- Note the current draw at this point and write it down here. \_\_\_\_\_mA
- Now, adjust R2, the Bias pot, by turning clockwise to increase the current drawn by the amplifier to be 90-100 milliamps greater than the initial current recorded above. For example, if the initial current was 60mA then you should adjust R2 until the current drawn is in the range of 150 to 160mA. Should you note oscillation or rapid on off switching of relays, try reducing the bias current by 5- 10mA or and retest. This is most likely to occur on lower frequency bands such as 80 or 40M where the gain is highest.

## Troubleshooting

If the Amplifier doesn't seem to be working follow the troubleshooting guide below to diagnose the problem.

- 1). Check that the parts are correctly installed
- 2). Check the soldering for missed, cold joints or shorts.
- 3). If the Amplifier keys when grounding pin 3 of SV1 but not from the RF input, check that C1 is the correct value for the band for which the amplifier is built.
- 4). Check that your exciter is outputting sufficient power to key the amplifier. IF using very low power exciters, it is recommended to use the keying control input on SV1 PIN3 to manually key the amplifier.
- 5). Check that you are operating on the correct band. The amplifier is single band. While it may operate on bands LOWER than the band it was built for, the harmonic content will be too high. It will NOT operate on a higher band than what the output low pass filter network was built for.
- 6). If there is no receive signals, check that the coax jumper is installed on the back of the Amplifier PCB.
- 7) Check the power draw of the amplifier. Maximum should be less than 3A and typically approximately 1-2 Amps when keyed. If bias is too high, the measured current draw may exceed 2A. In this case, recheck the bias setting and adjust if needed. Bias should also be reduced if oscillation or rapid on-off switching of relays is noted.

# Schematic Diagram

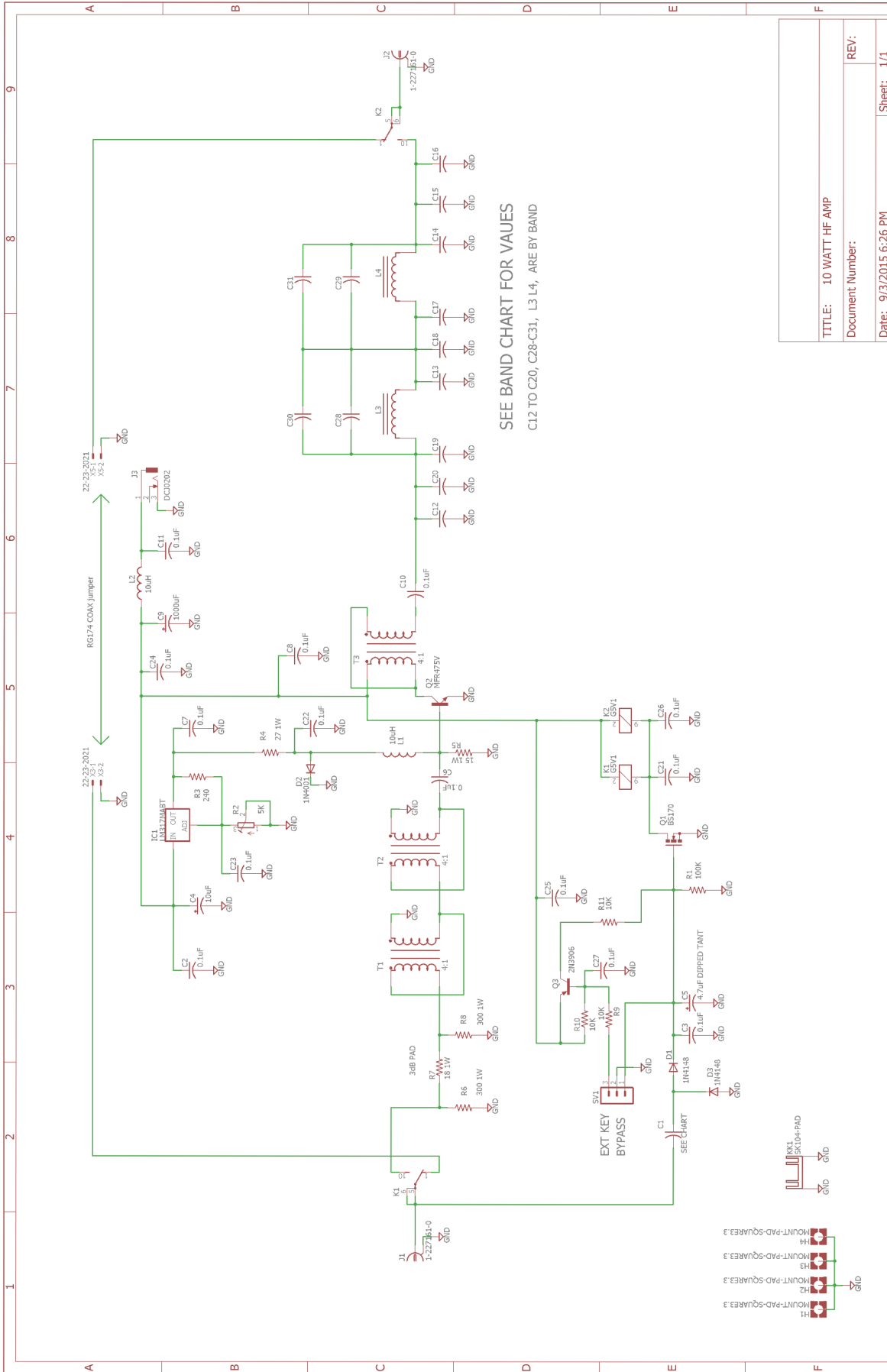

TITLE: 10 WATT HF AMP	REV:
Document Number:	
Date: 9/3/2015 6:26 PM	Sheet: 1/1

# Appendix 1: Low Pass Filter Response

## 20M

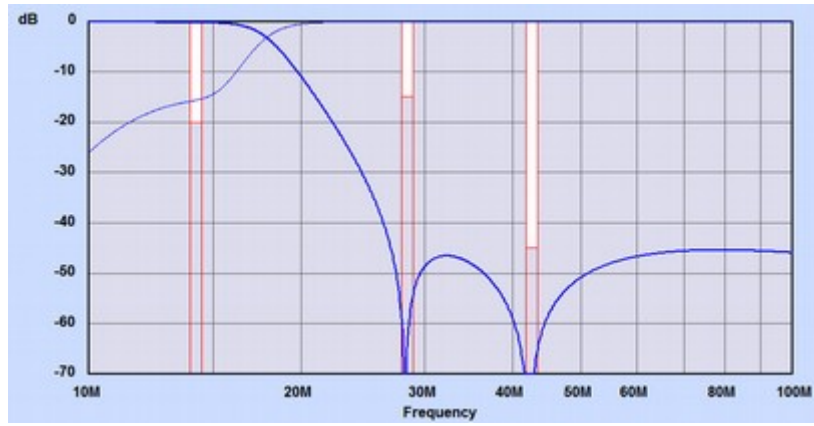

## 30M

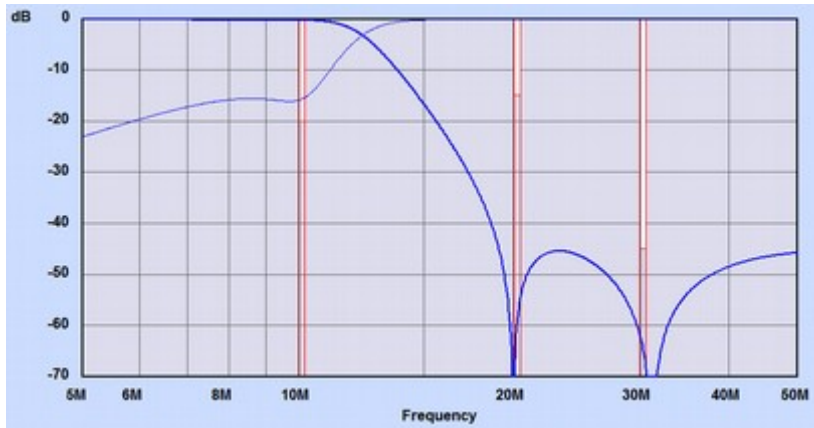

## 40M

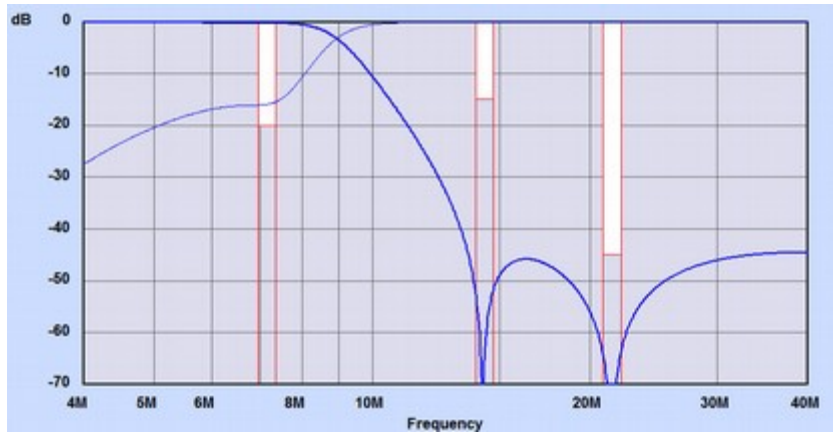

## Appendix 2 Identification of Capacitors

The capacitors used in the output filters for this kit follow the standard labeling convention

The first two digits are the value and the 3<sup>rd</sup> digit is the multiplier as shown above.

Typically, a 22pF capacitor will be marked 220 and a 220pF capacitor would be marked 221.

Occasionally, 2 digit value capacitors may just be marked with the value such as 22, 39, etc.

It is recommended to verify the capacitance with a capacitance meter whenever possible.

We verify the values of the filter capacitors for this kit but if you have any questions about the parts in your kit, please contact us.